

MINIMUM HOUSE FOUNDATION STANDARDS
Mesa County Building Department

EXAMPLE

Note: Non-expansive
Soils only.

GIVEN:

One story brick veneer with crawl space
Allowable soil pressure = 1500 psf hw = 3'-0"
Interior piers space at 12'-0" o.c.
L = 28'-0"

FIND: Minimum foundation required from tables

- Step #1 Determine weight of house above foundations. From Sheet 1, the reaction to the exterior wall (REW) = 1530 prf and the reaction to the interior wall (RIW) = 700 prf. The reaction to an interior pier spaced at 12'-0" centers would be $12 \times 700 = 8400$ lbs.
- Step #2 Determine minimum requirements for the exterior foundation. Since the house has brick veneer, the minimum thickness of the wall would probably be 8". From Sheet 2, the minimum horizontal reinforcing is 2-#4 bars (W1) top and bottom of wall with no intermediate horizontal reinforcing (W2) required. Minimum vertical reinforcing (W3) shall consist of 1-#4 spaced 48" o.c.
- Step #3 Determine the minimum size of the exterior wall footing. From Sheet 2, look up the D.L. of the wall as 300 prf. Add this to the exterior wall reaction of 1530 prf to obtain the reaction to the footing (R_f) of 1830 prf. From Sheet 4, the allowable soil pressure (Q_a) of 1500 psf and 1830 prf, look up a minimum footing size of 8" thick x 17" wide.
- Step #4 Sheet 5 is used to determine the minimum interior pier size. Using the 8400 lbs interior pier reaction determined in Step #1 and the allowable soil pressure of 1500 psf, Sheet 5 indicates a 31"x31" square by 10" thick concrete pier reinforced with 2-#4 reinforcing bars each way (equally spaced) is sufficient.

prf = pounds per linear foot
psf = pounds per square foot

MINIMUM HOUSE FOUNDATION STANDARDS
Mesa County Building Department

TABLE OF WALL REACTIONS

DESIGN LOADS:

ROOF LOAD = 30/10/10 = 50 psf total

FLOOR LOAD = 40/10 = 50 psf total

FRAME WALL (2x4, 16" o.c.) = 80 prf (8' wall height @ 10 psf)

4" MASONRY VENEER = 300 prf (8' wall height @ 37.5 psf)

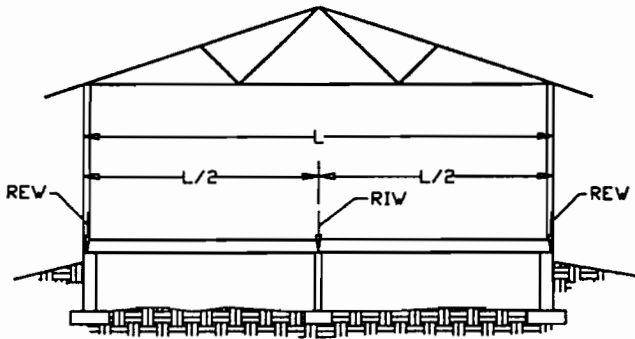

ONE STORY CROSS SECTION

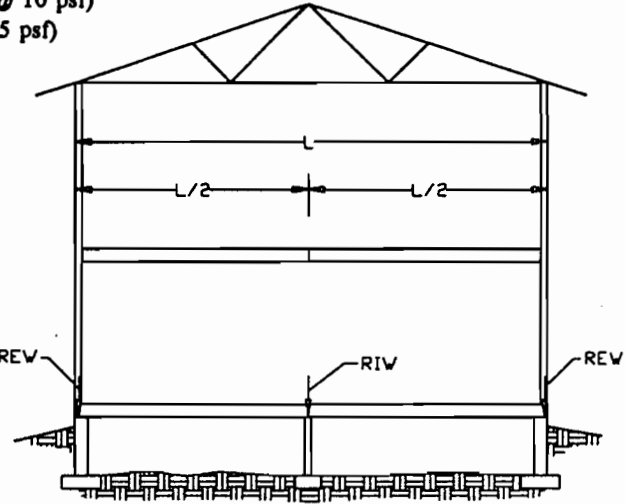

TWO STORY CROSS SECTION

LENGTH FEET	REW (prf)				RIW (prf)	
	ONE STORY (8' wall)*		TWO STORY (17' wall)*		ONE STORY	TWO STORY
	FRAME	VENEER**	FRAME	VENEER**		
20	930	1230	1270	1910	500	1065
22	1005	1305	1370	2010	550	1165
24	1080	1380	1470	2110	600	1265
26	1155	1455	1570	2210	650	1365
28	1230	1530	1670	2310	700	1465
30	1305	1605	1770	2410	750	1565
32	1380	1680	1870	2510	800	1665
34	1455	1755	1970	2610	850	1765
36	1530	1830	2070	2710	900	1865
38	1605	1905	2170	2810	950	1965
40	1680	1980	2270	2910	1000	2065

* For additional wall height, add 10 lbs/ft for each additional foot of frame wall height and 37.5 lbs/ft for each additional foot of masonry veneer in excess of specified height.

** Veneer = 4" masonry veneer

psf = pounds per square foot

prf = pounds per linear foot

MINIMUM HOUSE FOUNDATION STANDARDS
Mesa County Building Department

CRAWL SPACE FOUNDATION WALL

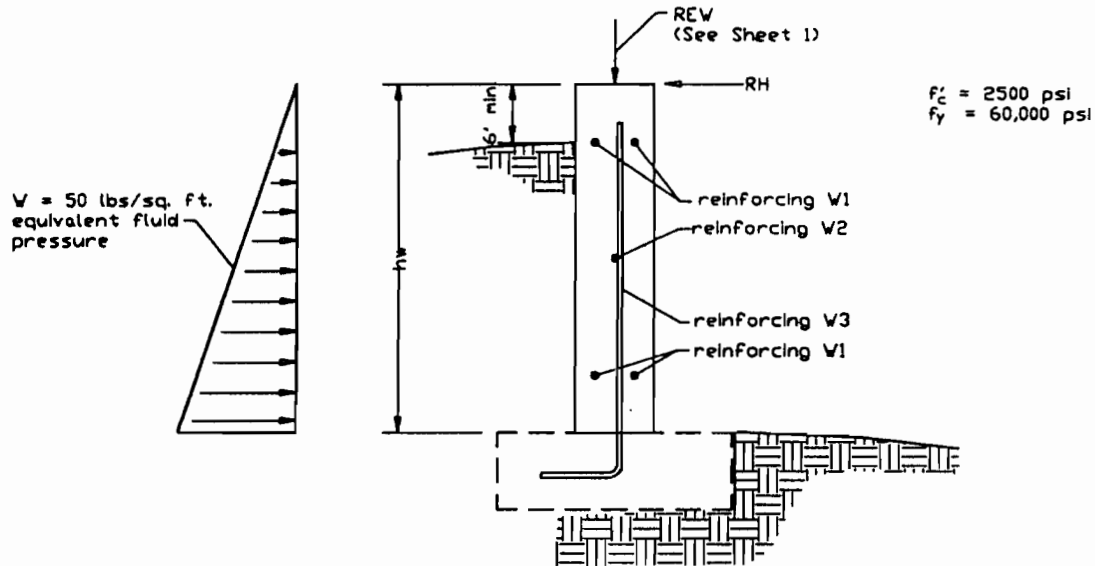

tw (inches)	hw (feet)	REINFORCING BARS			RH (prf)	D.L. WALL (prf)
		W1	W2	W3		
6	2	1 #5	—	#4 @ 48"	15	150
	3	1 #5	—	#4 @ 48"	45	225
	4	1 #5	1 #4	#4 @ 48"	90	300
8	2	2 #4	—	#4 @ 48"	15	200
	3	2 #4	—	#4 @ 48"	45	300
	4	2 #4	1 #4	#4 @ 48"	90	400
	5	2 #4	1 #4	#4 @ 48"	155	500
	6	2 #4	2 #4	#4 @ 48"	235	600
9	2	2 #4	—	#4 @ 48"	15	225
	3	2 #4	—	#4 @ 48"	45	340
	4	2 #4	1 #4	#4 @ 48"	90	450
	5	2 #4	1 #4	#4 @ 48"	155	565
	6	2 #4	2 #4	#4 @ 48"	235	675

RH = Restraining force to be furnished by floor system in lbs. per L.F. of wall. Floor system must be in place before foundation is backfilled.

DL = grade beam dead load (pounds per linear foot)

MINIMUM HOUSE FOUNDATION STANDARDS
Mesa County Building Department

BASEMENT FOUNDATION WALLS

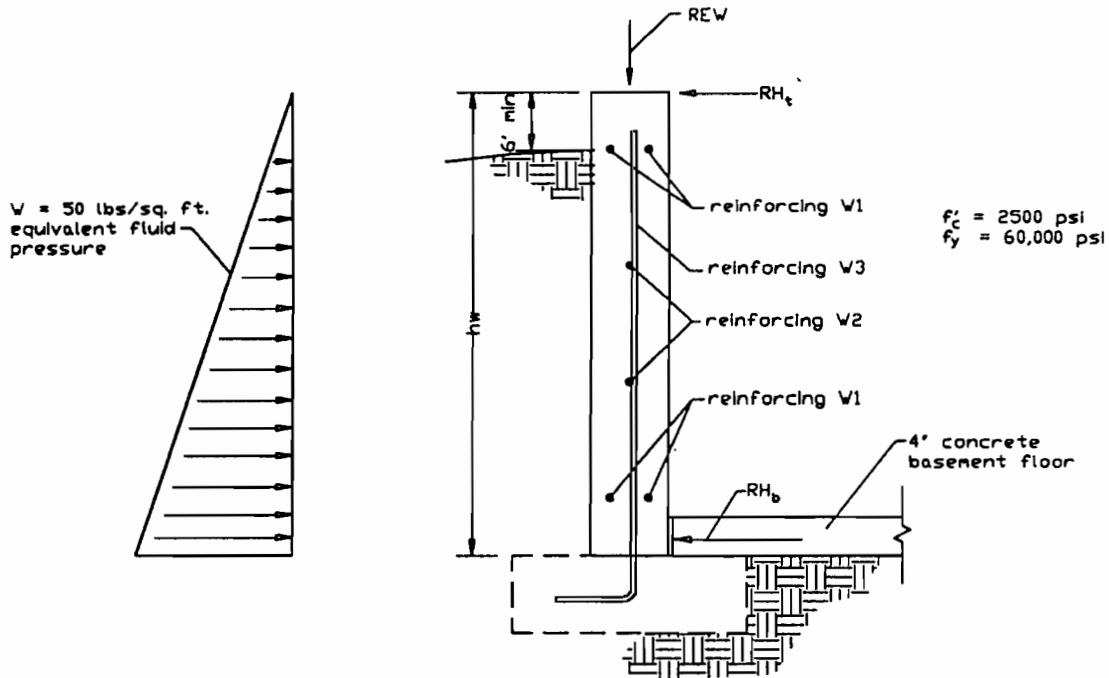

tw (inches)	hw (feet)	REINFORCING BARS			RH_t (prf)	RH_b (prf)	D.L. Wall (prf)
		W1	W2	W3			
8	6	2 #4	2 #4	#4 @ 48"	235	505	600
	8	2 #4	3 #4	#4 @ 21"	440	940	800
	10	2 #5	4 #5	#5 @ 16"	715	1505	1000
	12	2 #5	5 #5	#5 @ 8"	1060	2205	1200
9	6	2 #4	2 #4	#4 @ 48"	235	505	675
	8	2 #4	3 #4	#4 @ 24"	440	940	900
	10	2 #5	4 #5	#5 @ 18"	715	1505	1125
	12	2 #5	5 #5	#5 @ 9"	1060	2205	1350
10	6	2 #4	2 #4	#4 @ 48"	235	505	750
	8	2 #4	3 #4	#4 @ 24"	440	940	1000
	10	2 #5	4 #5	#5 @ 18"	715	1505	1250
	12	2 #5	5 #5	#5 @ 10"	1060	2205	1500

RH_t = Restraining force to be furnished by ground level floor system in lbs/linear ft. of wall. Floor system must be in place before foundation is backfilled.

RH_b = Restraining force to be furnished by basement floor system in lbs/linear ft. of wall. Floor system must be in place before foundation is backfilled.

D.L. = grade beam dead load (pounds per linear foot)

MINIMUM HOUSE FOUNDATION STANDARDS
Mesa County Building Department

FOOTING TABLE
CONTINUOUS WALL FOOTINGS
ALLOWABLE LOADS - PLAIN CONCRETE

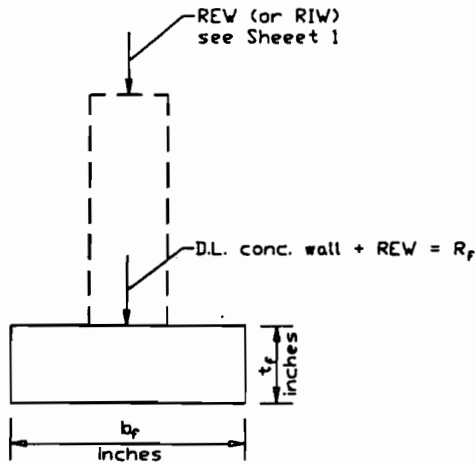

b _f	Q _a = 1000		Q _a = 1250		Q _a = 1500		Q _a = 1750		Q _a = 2000		Q _a = 2500	
	R _f	t _f	R _f	t _f	R _f	t _f	R _f	t _f	R _f	t _f	R _f	t _f
16	1150	8	1480	8	1820	8	2150	8	2480	8	3150	8
17	1210	8	1570	8	1920	8	2270	8	2630	8	3340	8
18	1270	8	1650	8	2020	8	2400	8	2770	8	3520	8
19	1330	8	1720	8	2120	8	2520	8	2910	8	3700	8
20	1380	8	1800	8	2220	8	2630	8	3050	8	3880	8
21	1440	8	1880	8	2310	8	2750	8	3190	8	4060	8
22	1490	8	1950	8	2410	8	2870	8	3330	8	4240	8
23	1540	8	2020	8	2500	8	2980	8	3460	8	4420	8
24	1600	8	2100	8	2600	8	3100	8	3600	8	4600	8
26	1630	9	2180	9	2720	9	3260	9	3800	9	4880	9
28	1650	10	2230	10	2820	10	3400	10	3980	10	5150	10
30	-*-		2260	11	2890	11	3510	11	4140	11	5390	11
32	-*-		-*-		2930	12	3600	12	4260	12	5600	12

R_f = Footing reaction in pounds per linear foot (Assuming non-expansive soils)

b_f = footing width (inches)

t_f = footing thickness (inches)

Q_a = allowable soil pressure in pounds per sq. ft.

-*- Transverse footing reinforcing required. Consult structural engineer.

MINIMUM HOUSE FOUNDATION STANDARDS
Mesa County Building Department

PIER TABLE - ALLOWABLE LOADS

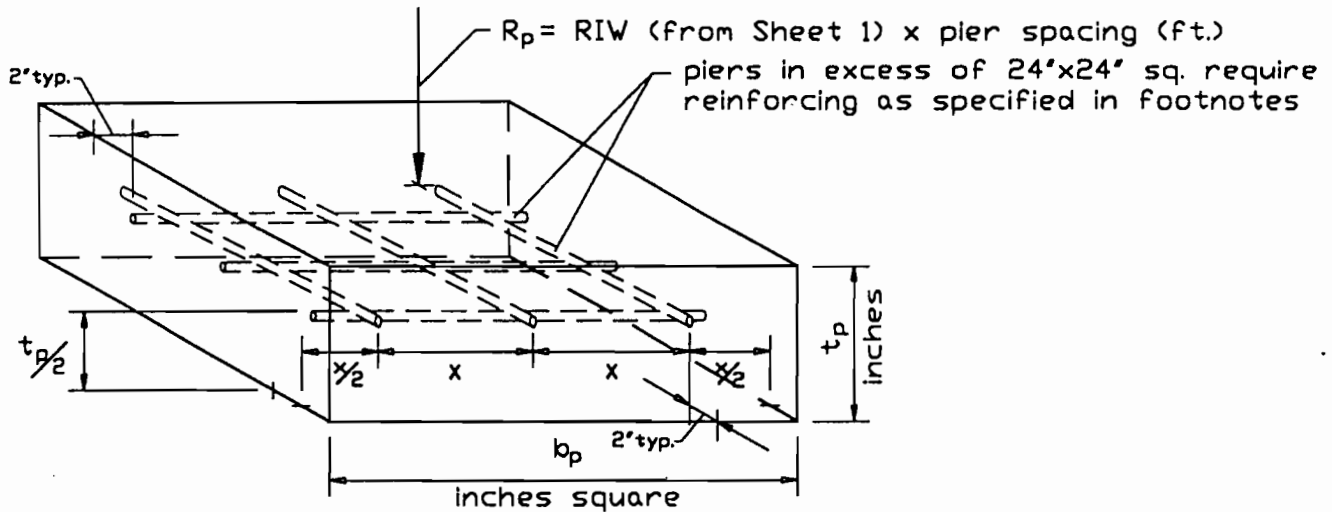

b_p	$Q_a = 1000$		$Q_a = 1250$		$Q_a = 1500$		$Q_a = 1750$		$Q_a = 2000$		$Q_a = 2500$	
	R_p	t_p	R_p	t_p	R_p	t_p	R_p	t_p	R_p	t_p	R_p	t_p
12x12	900	8	1250	8	1500	8	1750	8	2000	8	2500	8
14x14	1225	8	1565	8	1905	8	2245	8	2586	8	3266	8
16x16	1600	8	2044	8	2488	8	2933	8	3377	8	4266	8
18x18	2025	8	2587	8	3150	8	3712	8	4275	8	5400	8
20x20	2500	8	3194	8	3888	8	4583	8	5277	8	6666	8
22x22	2982	10	3823	10	4663	10	5503	10	6344	10	8024	10
24x24	3500	10	4500	10	5500	10	6500	10	7500	10	9500	10
25x25	3743	10*	4828	10*	5913	10*	6998	10*	8083	10*	10253	10*
26x26	4048	10*	5222	10*	6396	10*	7569	10*	8743	10*	11090	10*
27x27	4303	10*	5568	10*	6834	10*	8100	10*	9365	10*	11896	10**
28x28	4627	10*	5988	10*	7350	10*	8711	10*	10072	10*	12794	10**
29x29	4891	10*	6351	10*	7811	10*	9271	10*	10731	10**	13651	10**
30x30	5234	10*	6796	10*	8359	10*	9921	10*	11484	10**	14609	10**
31x31	5505	10*	7174	10*	8842	10*	10510	10**	12179	10**	15516	10**
32x32	5866	10*	7644	10*	9422	10*	11200	10**	12977	10**	16533	10**
33x33	6144	10*	8035	10*	9925	10**	11816	10**	13707	10**	17488	10***
34x34	6522	10*	8529	10*	10536	10**	12543	10**	14550	10**	18564	10***
35x35	6805	10*	8932	10*	11059	10**	13185	10**	15312	10**	19565	10***
36x36	7200	10*	9450	10*	11700	10**	13950	10**	16200	10**	20700	10***

R_p = Pier reaction in pounds (assuming non-expansive soils); calculated as RIW (from Sheet 1) multiplied by the pier spacing in feet.

b_p = pier width (square pier) (inches)

t_p = pier thickness (inches)

Q_a = allowable soil pressure in pounds per sq. ft.

Reinforcing Requirements

- * - provide 2-#4 each way equal spaced
- ** - provide 3-#4 each way equal spaced
- *** - provide 4-#4 each way equal spaced

MINIMUM HOUSE FOUNDATION STANDARDS

Mesa County Building Department

TABLE OF FOOTING SIZES

One Story Building/Non-expansive Soils - Monolithic Slab and Footing

DESIGN LOADS:

ROOF LOADS = 30/10/10 = 50 psf total
 FLOOR LOADS = 40/10 = 50 psf total
 FRAME WALL (2x4, 16' o.c.) = 80 prf
 (8' wall height @ 10 psf)
 4" MASONRY VENEER = 300 prf
 (8' wall height @ 37.5 psf)

psf = pounds per square foot
 prf = pounds per linear foot

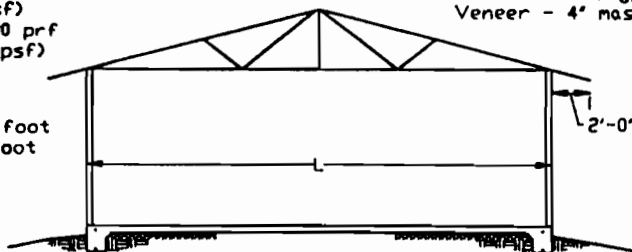

Q_a = soil bearing capacity = lbs/sq. ft.
 b_f is given in inches
 NR = Not recommended; requires additional reinforcing; consult structural engineer
 Veneer - 4" masonry veneer

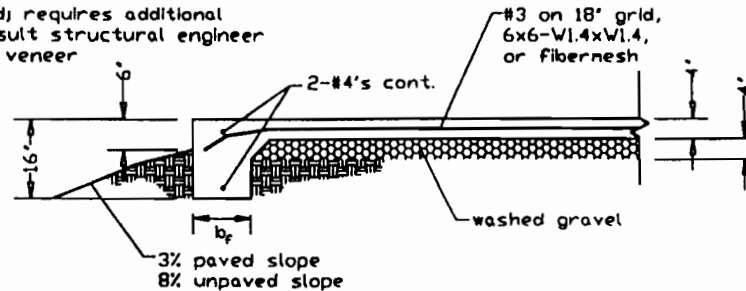

LENGTH (feet) L	ONE STORY - 8' WALL*											
	$Q_a = 1000$		$Q_a = 1250$		$Q_a = 1500$		$Q_a = 1750$		$Q_a = 2000$		$Q_a = 2500$	
	FRAME b_f	VENEER b_f	FRAME b_f	VENEER b_f	FRAME b_f	VENEER b_f	FRAME b_f	VENEER b_f	FRAME b_f	VENEER b_f	FRAME b_f	VENEER b_f
20	10	15	8	12	8	10	8	8	8	8	8	8
22	11	16	9	12	8	10	8	8	8	8	8	8
24	12	16	9	13	8	10	8	9	8	8	8	8
26	13	17	10	13	8	11	8	9	8	8	8	8
28	14	18	10	14	9	11	8	10	8	8	8	8
30	14	18	11	14	9	12	8	10	8	9	8	8
32	15	NR	12	15	10	12	8	10	8	9	8	8
34	16	NR	12	16	10	13	8	11	8	9	8	8
36	17	NR	13	16	10	13	9	11	8	10	8	8
38	17	NR	13	17	11	14	9	11	8	10	8	8
40	18	NR	14	17	11	14	10	12	8	10	8	8

*For additional wall height, add 10 lbs/ft for each additional foot of frame wall height and 37.5 lbs/ft for each additional foot of masonry veneer in excess of specified height.

MINIMUM HOUSE FOUNDATION STANDARDS

Mesa County Building Department

TABLE OF FOOTING SIZES

Two Story Building/Non-expansive Soils - Monolithic Slab and Footing

DESIGN LOADS:

ROOF LOADS = 30/10/10 = 50 psf total
 FLOOR LOADS = 40/10 = 50 psf total
 FRAME WALL (2x4, 16' o.c.) = 80 prf
 (8' wall height @ 10 psf)
 4' MASONRY VENEER = 300 prf
 (8' wall height @ 37.5 psf)

psf = pounds per square foot
 prf = pounds per linear foot
 b_{1F} = footing width for frame
 b_{1V} = footing width for frame with 4' masonry veneer
 b_{2C} = footing width for center bearing wall

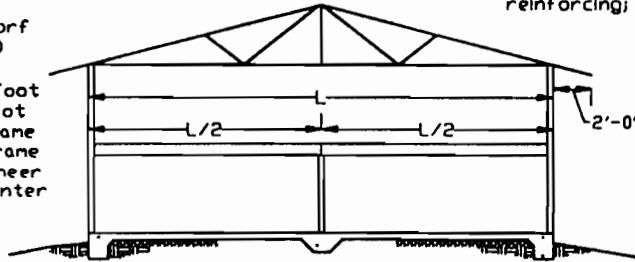

Q_a = soil bearing capacity = lbs/sq. ft.
 b_f is given in inches
 NR = Not recommended; requires additional reinforcing; consult structural engineer

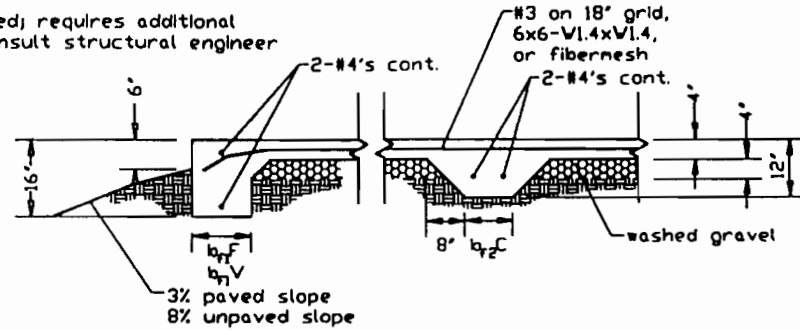

LENGTH (feet) L	TWO STORY - 17' WALL*																	
	Q _a = 1000			Q _a = 1250			Q _a = 1500			Q _a = 1750			Q _a = 2000			Q _a = 2500		
	b_{1F}	b_{1V}	b_{2C}	b_{1F}	b_{1V}	b_{2C}	b_{1F}	b_{1V}	b_{2C}	b_{1F}	b_{1V}	b_{2C}	b_{1F}	b_{1V}	b_{2C}	b_{1F}	b_{1V}	b_{2C}
20	16	NR	8	12	NR	8	10	16	8	8	13	8	8	11	8	8	9	8
22	17	NR	9	13	NR	8	11	16	8	9	14	8	8	12	8	8	9	8
24	18	NR	10	14	NR	8	11	17	8	9	14	8	8	12	8	8	10	8
26	NR	NR	10	15	NR	8	12	18	8	10	15	8	9	13	8	8	10	8
28	NR	NR	11	15	NR	9	13	18	8	11	16	8	9	13	8	8	11	8
30	NR	NR	12	16	NR	10	13	NR	8	11	16	8	10	14	8	8	11	8
32	NR	NR	13	17	NR	10	14	NR	8	12	17	8	10	14	8	8	11	8
34	NR	NR	13	18	NR	10	15	NR	9	12	17	8	11	15	8	8	12	8
36	NR	NR	14	NR	NR	11	15	NR	9	13	18	8	11	15	8	9	12	8
38	NR	NR	15	NR	NR	11	16	NR	9	14	18	8	12	16	8	9	13	8
40	NR	NR	15	NR	NR	12	17	NR	10	14	NR	8	12	16	8	10	13	8

*For additional wall height, add 10 lbs/ft for each additional foot of frame wall height and 37.5 lbs/ft for each additional foot of masonry veneer in excess of specified height.